

REV	ZONE	REVISION	DATE

# INT13-DP2111/S04

## 材料和技术参数 Material and spec

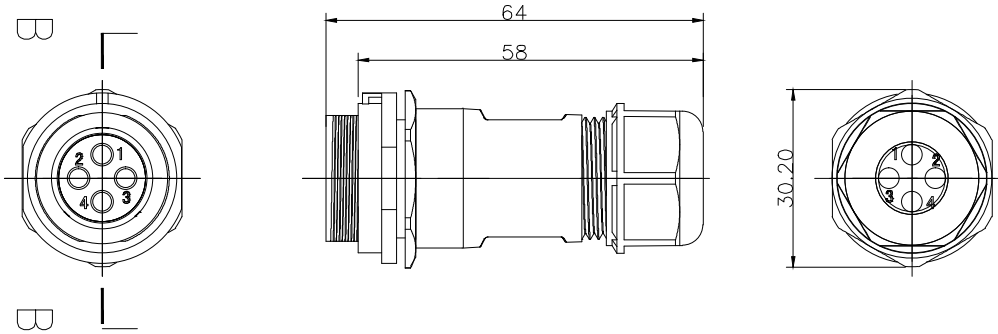

产品类型	Product model	连接器	Connector
接插方式	Coupling	螺纹锁紧	Threaded
外壳材料	Shell material	热塑材料	PPO, PA66 阻燃等级:V-0 PPO, Nylon66 fire resistance:V-0
绝缘体	Insert material	热塑材料	PPS 耐高温 260°C PPS man temperature 260°C
接触件材料	Contact material	铜镀金	Brass with gold plating
接线方式	Termination	INT13-DP21:焊接/压接	INT13-DP21:solder/crimp
电缆直径	Cable outer diameter range	INT13-DP21B:7-12mm	
防护等级	IP rating	IP68	
接插次数	Mating cycle	500 times	
温度范围	Temperature range	-25 °C -- +85 °C	
绝缘电阻MΩ	Insulation resistance M	2000	

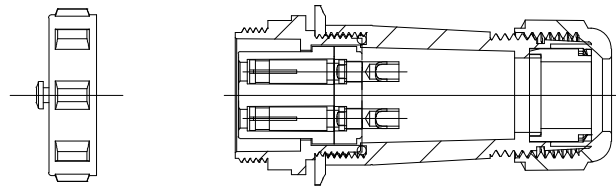

SECTION B-B

## 焊接芯件芯数排列及技术特性表 Solder contact arrangement and spec

芯数	Number of contact	4
插针绝缘体正面图	Male contact face view	
额定电流A	Rated current (A)	30A
接触件直径	Contact diameter	2.8*4
接线方式	Termination	焊接/螺丝压接 solder/crimp
工作电压(AC.V)	Rated voltage(AC.V)	500V
耐压(AC.V) 1 min	Test voltage(AC.V) 1 min	1500V
接触电阻 mΩ	Contact resistance mΩ	1
线规 mm <sup>2</sup> /AWG	Wire size solder mm <sup>2</sup> /AWG	<4.17/11 .
	螺丝压接线规 mm <sup>2</sup> /AWG	<1.5/15 .
	Wire size for screw ceimp mm <sup>2</sup> /AWG	



深圳市茵特电子科技有限公司  
SHENZHEN INTE-AUTO CO.,LTD

COMPUTER NO.

INT13-DP21 PULG

UNIT

mm

SCALE

1:1

PART NAMF

INT13-DP2111/S04

APPD.

Lee

CKD.

LWJ

LZG

DATE

2024/6/1

TOLERANCE

×. ±0.05  
.x ±0.05  
.xx ±0.02

PART NO.

4Pin-Solder

PEV

A0

MODEL

Waterproof  
Connector

PAGE 1 OF 1

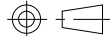

1

2

3

4

5

6

7

8