

# INT13-FP2114/S07L

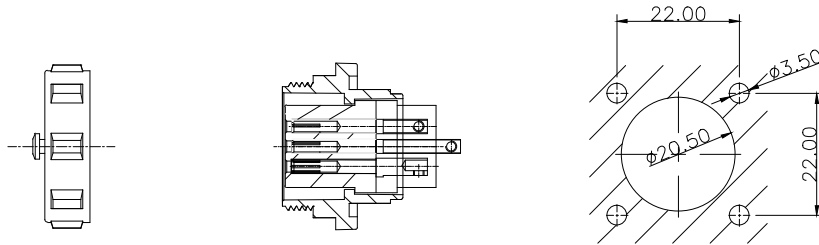
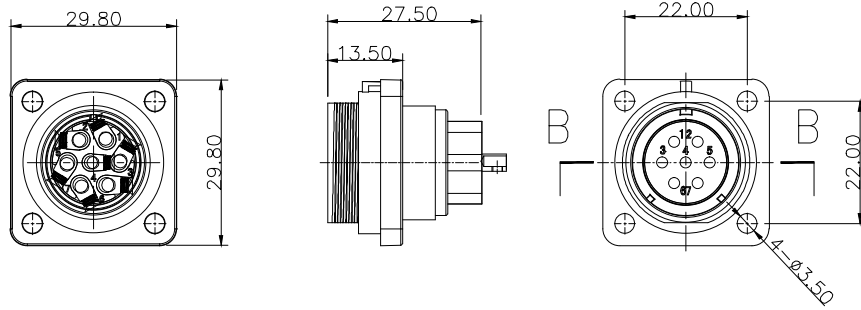

SECTION B-B

开孔尺寸

REV	ZONE	REVISION	DATE

## 材料和技术参数 Material and spec

产品类型	Product model	连接器	Connector
接插方式	Coupling	螺纹锁紧	Threaded
外壳材料	Shell material	热塑材料	PPO, PA66 阻燃等级:V-0
			PP0, Nylon66 fire resistance:V-0
绝缘体	Insert material	热塑材料	PPS 耐高温 260°C
			PPS man temperature 260°C
接触件材料	Contact material	铜镀金	Brass with gold plating
接线方式	Termination	INT13-FP21:焊接/压接	INT13-FP21:solder/crimp
电缆直径	Cable outer diameter range	INT13-FP21B:7-12mm	
防护等级	IP rating	IP68	
接插次数	Mating cycle	500 times	
温度范围	Temperature range	-25 °C -- +85 °C	
绝缘电阻MΩ	Insulation resistance M	2000	

## 焊接芯件芯数排列及技术特性表 Solder contact arrangement and spec

芯数 Number of contact	7
插针绝缘体正面图 Male contact face view	
额定电流A Rated current (A)	15A
接触件直径 Contact diameter	1.8*7
接线方式 Termination	焊接/螺丝压接 solder/crimp
工作电压(AC.V) Rated voltage(AC.V)	500V
耐压(AC.V) 1 min Test voltage(AC.V) 1 min	1500V
接触电阻 μΩ Contact resistance μΩ	2.5
线规 mm <sup>2</sup> /AWG Wire size solder mm <sup>2</sup> /AWG	< 2/14
螺丝压接线规 mm <sup>2</sup> /AWG Wire size for screw ceimp mm <sup>2</sup> /AWG	

**INTE-AUTO**

深圳市茵特电子科技有限公司  
SHENZHEN INTE-AUTO CO.,LTD

COMPUTER NO.

UNIT

SCALE

PART NAMF

INT13-FP21 Receptacle

mm

1:1

INT13-FP2114/S07L

APPD.

CKD.

DATE

TOLERANCE

PART NO.

PEV

MODEL

Waterproof  
Connector

PAGE 1 OF 1

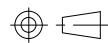

Lee

LWJ

LZG

2024/6/1

x. ±0.05  
.xx ±0.02

7Pin-Screw

A0