

INT13-TP1310/P01

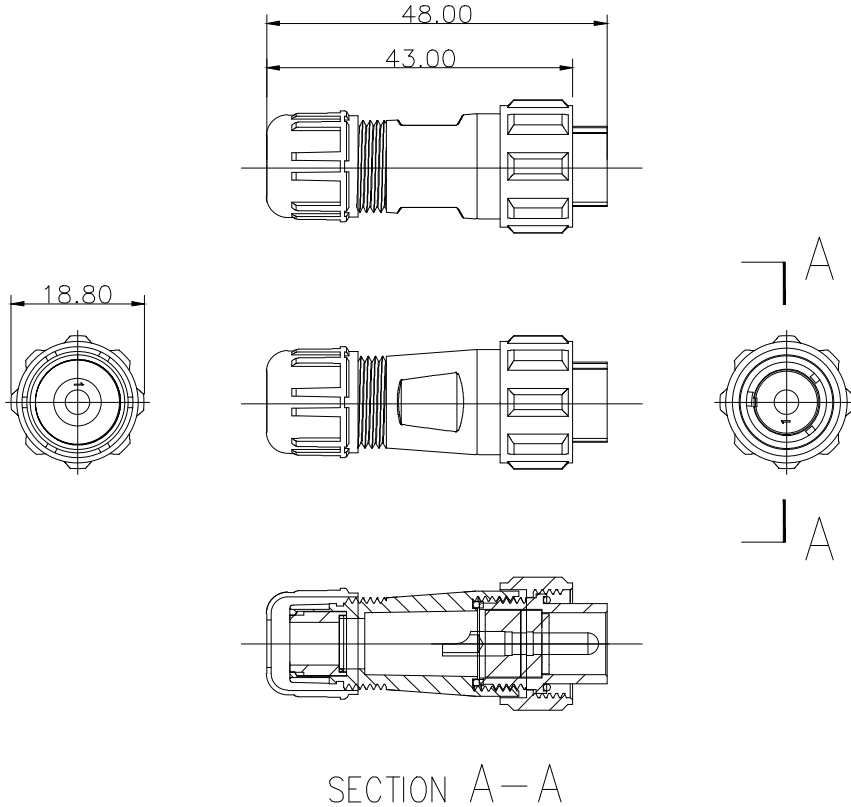

REV	ZONE	REVISION	DATE

材料和技术参数 Material and spec

产品类型	Product model	连接器	Connector
接插方式	Coupling	螺纹锁紧	Threaded
外壳材料	Shell material	热塑材料	PP0, PA66 阻燃等级:V-0 PP0, Nylon66 fire resistance:V-0
绝缘体	Insert material	热塑材料	PPS 耐高温 260°C PPS man temperature 260°C
接触件材料	Contact material	铜镀金	Brass with gold plating
接线方式	Termination	INT-13: Solder	
电缆直径	Cable outer diameter range	INT13-TP13A: 4-6.5mm	INT13-TP13B: 5-8mm
防护等级	IP rating	IP68	
接插次数	Mating cycle	500 times	
温度范围	Temperature range	-25 °C -- +85 °C	
绝缘电阻MΩ	Insulation resistance M	2000	

焊接芯件芯数排列及技术特性表 Solder contact arrangement and spec

芯数 Number of contact	1
插针绝缘体正面图 Male contact face view	
额定电流A Rated current (A)	30A
接触件直径 Contact diameter	3.0*1
工作电压 (AC. V) Rated voltage (AC. V)	500
耐压 (AC. V) 1 min Test voltage (AC. V) 1 min	1500
接触电阻 mΩ Contact resistance mΩ	0.5
线规 mm²/AWG Wire size solder mm²/AWG	≤4/11

INTE-AUTO

深圳市茵特电子科技有限公司
SHENZHEN INTE-AUTO CO.,LTD

COMPUTER NO.

INT13-TP13 PULG

UNIT

mm

SCALE

1:1

PART NAMF

INT13-TP1310/P01

APPD.

Lee

CKD.

LWJ

DATE

2024/6/1

TOLERANCE

.x ±0.05
.xx ±0.02

PART NO.

1Pin-Solder

PEV

A0

MODEL

Waterproof
Connector

PAGE 1 OF 1

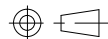

1

2

3

4

5

6

7

8