

INT13-TP1310/P06

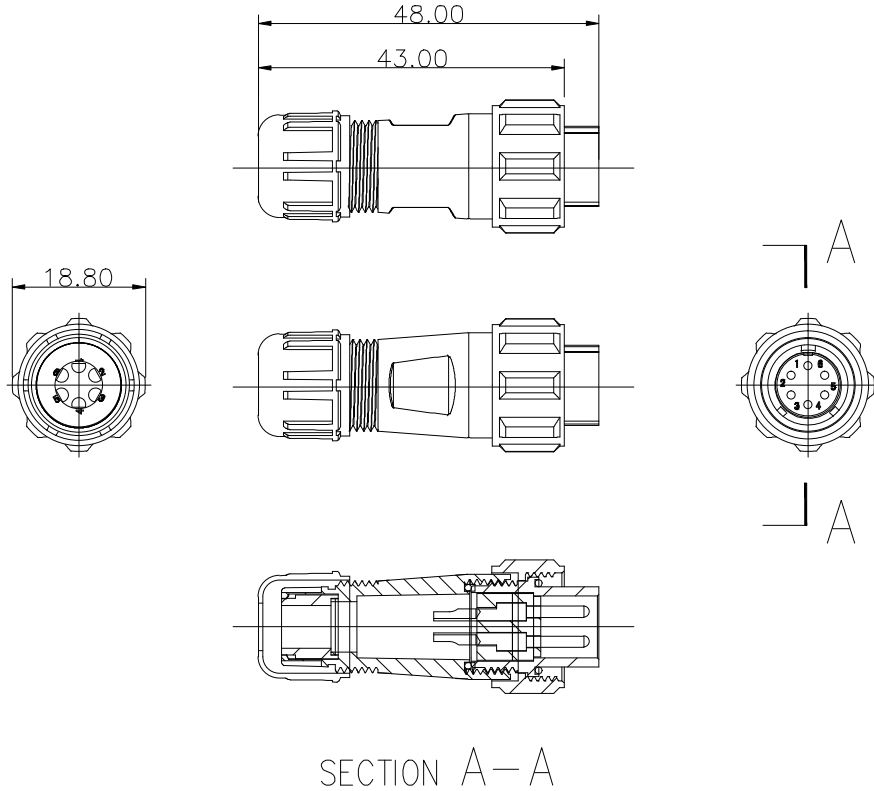

REV	ZONE	REVISION	DATE

Material and spec

产品类型	Product model	连接器	Connector
接插方式	Coupling	螺纹锁紧	Threaded
外壳材料	Shell material	热塑材料	PP0, PA66 阻燃等级:V-0 PP0, Nylon66 fire resistance:V-0
绝缘体	Insert material	热塑材料	PPS 耐高温 260°C PPS man temperature 260°C
接触件材料	Contact material	铜镀金	Brass with gold plating
接线方式	Termination	INT-13: Solder	
电缆直径	Cable outer diameter range	INT13-TP13A: 4-6.5mm	INT13-TP13B: 5-8mm
防护等级	IP rating	IP68	
接插次数	Mating cycle	500 times	
温度范围	Temperature range	-25 °C -- +85 °C	
绝缘电阻MΩ	Insulation resistance M	2000	

焊接芯件芯数排列及技术特性表

Solder contact arrangement and spec

芯数 Number of contact	6
插针绝缘体正面图 Male contact face view	
额定电流A Rated current (A)	5A
接触件直径 Contact diameter	1.0*6
工作电压 (AC. V) Rated voltage (AC. V)	125
耐压 (AC. V) 1 min Test voltage (AC. V) 1 min	1000
接触电阻 mΩ Contact resistance mΩ	5
线规 mm²/AWG Wire size solder mm²/AWG	≤0.785/18

INTE-AUTO

深圳市茵特电子科技有限公司
SHENZHEN INTE-AUTO CO.,LTD

COMPUTER NO.

INT13-TP13 PULG

UNIT

mm

SCALE

1:1

PART NAMF

INT13-TP1310/P06

APPD.

Lee

CKD.

LWJ

LZG

DATE

2024/6/1

TOLERANCE

.x ±0.05
.xx ±0.02

PART NO.

6Pin-Solder

PEV

A0

MODEL

Waterproof
Connector

PAGE 1 OF 1

