

INT13-TP2110/P062

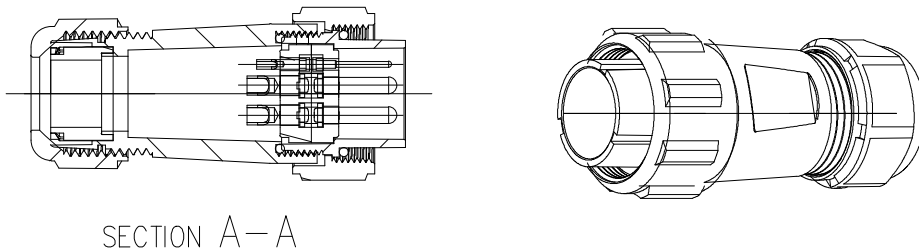
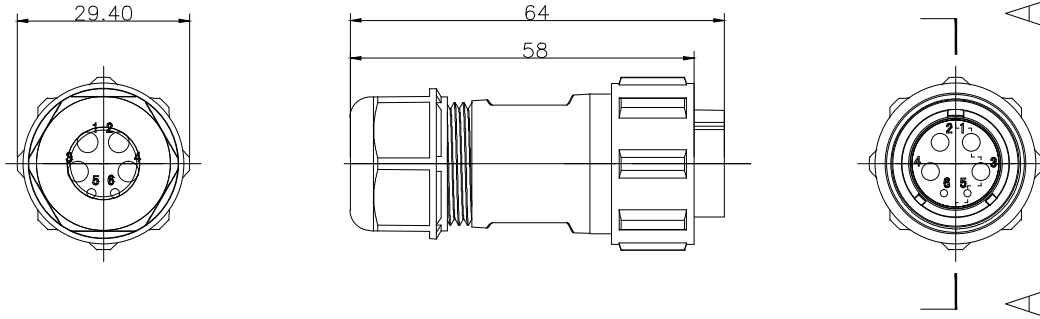

产品类型	Product model	连接器	Connector
接插方式	Coupling	螺纹锁紧	Threaded
外壳材料	Shell material	热塑材料	PPO, PA66 阻燃等级:V-0 PPO, Nylon66 fire resistance:V-0
绝缘体	Insert material	热塑材料	PPS 耐高温 260°C PPS man temperature 260°C
接触件材料	Contact material	铜镀金	Brass with gold plating
接线方式	Termination	INT13-TP21:焊接/压接	INT13-TP21:solder/crimp
电缆直径	Cable outer diameter range	INT13-TP21B:7-12mm	
防护等级	IP rating	IP68	
接插次数	Mating cycle	500 times	
温度范围	Temperature range	-25 °C -- +85 °C	
绝缘电阻MΩ	Insulation resistance M	2000	

焊接芯件芯数排列及技术特性表 Solder contact arrangement and spec

芯数 Number of contact	6B
插针绝缘体正面图 Male contact face view	
额定电流A Rated current (A)	30A/5A
接触件直径 Contact diameter	2.8*4 1.0*2
接线方式 Termination	焊接 solder
工作电压(AC.V) Rated voltage(AC.V)	500V/400V
耐压(AC.V) 1 min Test voltage(AC.V) 1 min	1500V
接触电阻 μΩ Contact resistance μΩ	1 / 5
线规 mm ² /AWG Wire size solder mm ² /AWG	<0.785/18. <4.17/11.
螺丝压接线规 mm ² /AWG Wire size for screw ceimp mm ² /AWG	

INTE-AUTO

深圳市茵特电子科技有限公司
SHENZHEN INTE-AUTO CO.,LTD

COMPUTER NO.

INT13-TP21 PULG

UNIT

mm

SCALE

1:1

PART NAMF

INT13-TP2110/P062

APPD.

Lee

CKD.

LWJ

DATE

LZG

DATE

2024/6/1

TOLERANCE

×. ±0.05
.× ±0.02

PART NO.

6Pin-Solder

PEV

A0

MODEL

Waterproof
Connector

PAGE 1 OF 1

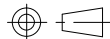

1

2

3

4

5

6

7

8