

REV	ZONE	REVISION	DATE

INT13-ZP2112/S02

材料和技术参数 Material and spec

产品类型	Product model	连接器	Connector
接插方式	Coupling	螺纹锁紧	Threaded
外壳材料	Shell material	热塑材料	PPO, PA66 阻燃等级:V-0 PPO, Nylon66 fire resistance:V-0
绝缘体	Insert material	热塑材料	PPS 耐高温 260°C PPS man temperature 260°C
接触件材料	Contact material	铜镀金	Brass with gold plating
接线方式	Termination	INT13-ZP21:焊接/压接 INT13-ZP21:solder/crimp	
电缆直径	Cable outer diameter range	INT13-ZP21B:7-12mm	
防护等级	IP rating	IP68	
接插次数	Mating cycle	500 times	
温度范围	Temperature range	-25 °C -- +85 °C	
绝缘电阻MΩ	Insulation resistance M	2000	

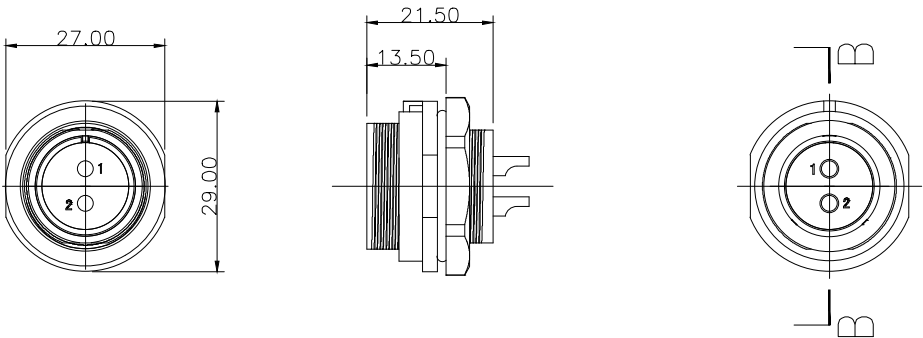

焊接芯件芯数排列及技术特性表 Solder contact arrangement and spec

芯数	Number of contact	2
插针绝缘体正面图	Male contact face view	
额定电流A	Rated current (A)	30A
接触件直径	Contact diameter	2.8*2
接线方式	Termination	焊接/螺丝压接 solder/crimp
工作电压(AC.V)	Rated voltage(AC.V)	500V
耐压(AC.V) 1 min	Test voltage(AC.V) 1 min	1500V
接触电阻 mΩ	Contact resistance mΩ	1
线规 mm ² /AWG	Wire size solder mm ² /AWG	<4.17/11 .
	螺丝压接线规 mm ² /AWG	<1.5/15 .
	Wire size for screw ceimp mm ² /AWG	

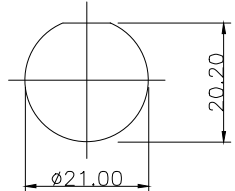
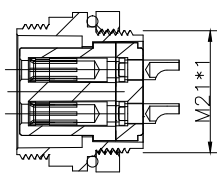
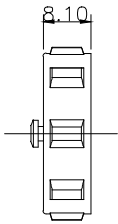

SECTION B-B

开孔尺寸
机箱板最厚3.0



深圳市茵特电子科技有限公司
SHENZHEN INTE-AUTO CO.,LTD

COMPUTER NO.

UNIT

SCALE

PART NAMF

INT13-ZP21 Receptacle

mm

1:1

INT13-ZP2112/S02

APPD.

CKD.

DATE

TOLERANCE

PART NO.

PEV

MODEL

Waterproof Connector

PAGE 1 OF 1

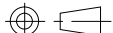

Lee

LWJ

LZG

2024/6/1

×.
.× ±0.05
.×× ±0.02

2Pin-Solder

A0