

INT13-ZP2112/S061

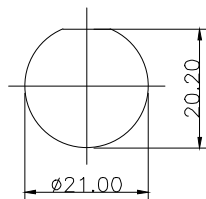
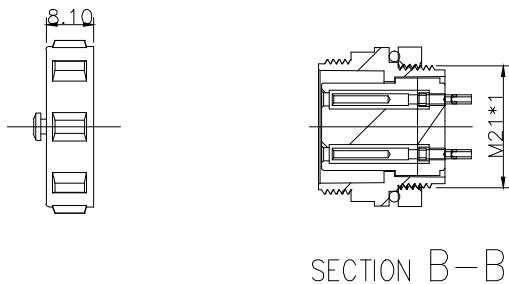
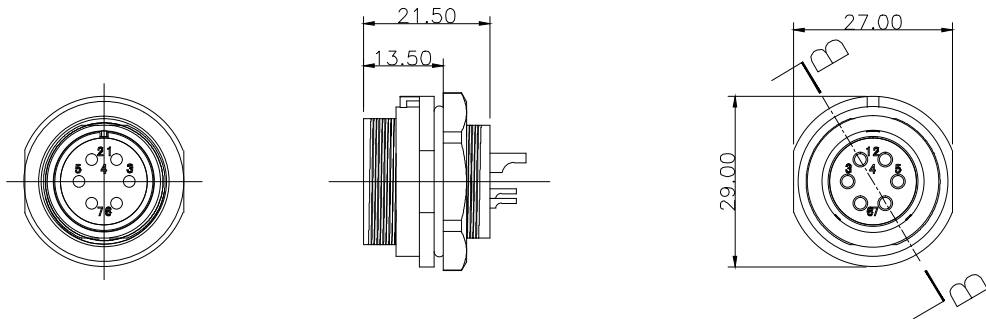

开孔尺寸
机箱板最厚3.0

| | | | |
|-----|------|----------|------|
| REV | ZONE | REVISION | DATE |
| | | | |

材料和技术参数 Material and spec

| 产品类型 | Product model | 连接器 | Connector |
|--------|----------------------------|--|-------------------------|
| 接插方式 | Coupling | 螺纹锁紧 | Threaded |
| 外壳材料 | Shell material | 热塑材料 PP0, PA66 阻燃等级:V-0 PP0, Nylon66 fire resistance:V-0 | |
| 绝缘体 | Insert material | 热塑材料 PPS 耐高温 260°C PPS max temperature 260°C | |
| 接触件材料 | Contact material | 铜镀金 | Brass with gold plating |
| 接线方式 | Termination | INT13-ZP21:焊接/压接 INT13-ZP21:solder/crimp | |
| 电缆直径 | Cable outer diameter range | INT13-ZP21B:7-12mm | |
| 防护等级 | IP rating | IP68 | |
| 接插次数 | Mating cycle | 500 times | |
| 温度范围 | Temperature range | -25 °C — +85 °C | |
| 绝缘电阻MΩ | Insulation resistance M | 2000 | |

焊接芯件芯数排列及技术特性表 Solder contact arrangement and spec

| 芯数 | 6A |
|---|--------------|
| Number of contact | 6A |
| 插针绝缘体正面图 Male contact face view | |
| 额定电流A Rated current (A) | 15A |
| 接触件直径 Contact diameter | 1.8*6 |
| 接线方式 Termination | 焊接 solder |
| 工作电压 (AC.V) Rated voltage (AC.V) | 500V |
| 耐压 (AC.V) 1 min Test voltage (AC.V) 1 min | 1500V |
| 接触电阻 mΩ Contact resistance mΩ | 2.5 |
| 线规 mm²/AWG Wire size solder mm²/AWG | < 2/14 . |
| 螺丝压接线规 mm²/AWG Wire size for screw ceimp mm²/AWG | |



深圳市茵特电子科技有限公司
SHENZHEN INTE-AUTO CO.,LTD

COMPUTER NO.

INT13-ZP21 Receptacle

UNIT

mm

SCALE

1:1

PART NAMF

INT13-ZP2112/S061

APPD.

Lee

CKD.

LWJ

DATE

LZG

DATE

2024/6/1

TOLERANCE

.x ±0.05
.xx ±0.02

PART NO.

6Pin-Solder

PEV

A0

MODEL

Waterproof
Connector

PAGE 1 OF 1

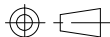

1

2

3

4

5

6

7

8